

MAXIM

MAX3690 Evaluation Kit

Evaluates: MAX3690

General Description

The MAX3690 evaluation kit (EV kit) is an assembled surface-mount demonstration board that provides easy evaluation of the MAX3690 622Mbps serializer with TTL input, clock synthesis, and differential PECL output.

Component List

DESIGNATION	QTY	DESCRIPTION
C4–C12, C16–C21	15	0.1 μ F, 25V min, 10% ceramic capacitors (0603)
C13, C22	2	1 μ F, 10V min, 10% ceramic capacitors (0805) X7R
C14	1	1 μ F, 25V min, 10% ceramic capacitor (0805)
C15*	1	33 μ F \pm 10%, 10V min tantalum cap AVX TAJD336K010
C2, C3, R2, R11, JU1, JU2, JU4	0	Do not install
L1–L5*	5	56nH inductors Coilcraft 0805CS-560XKBC
R3, R4	2	27 Ω , 5% resistors (0603)
R5, R6	2	220 Ω , 5% resistors (0603)
R7, R8	2	130 Ω , 5% resistors (0603)
R9, R10	2	24 Ω , 5% resistors (0603)
R12	1	20k Ω , 5% resistor (0603)
PCLKI, PD0–PD7, PCLKO	10	SMB connectors (PC mount) Suhner 82 SMB-50-0-1/111
RCLK, SD+, SD-	3	SMA connectors (PC mount) E.F. Johnson 142-0701-206 or Digi-Key J495-ND
VCC, GND	2	Test points Mouser 151-203
JU3	1	2x2 pin header (0.1" centers) Digi-Key S2012-36-ND
None	1	Shunt Digi-Key S9000-ND
U1*	1	MAX3690ECJ (32 TQFP)
None	1	MAX3690 EV kit circuit board, Rev. B
None	1	MAX3690 data sheet*

* Supplied by Maxim.

Features

- ◆ **+3.3V Single Supply**
- ◆ **77.76MHz Overhead Generation Clock Reference Frequency**
- ◆ **Selectable Input Clock Reference Frequencies**
 - 77.76MHz
 - 51.84MHz
 - 38.88MHz
- ◆ **Fully Assembled and Tested Surface-Mount Board**

Ordering Information

PART	TEMP. RANGE	IC PACKAGE
MAX3690EVKIT	-40°C to +85°C	32 TQFP

Component Suppliers

SUPPLIER	PHONE	FAX
Coilcraft	847-639-6400	847-639-1469
Sprague	603-224-1961	603-224-1430

Note: Please indicate that you are using the MAX3690 when contacting these component suppliers.

Detailed Description

The MAX3690 EV kit simplifies evaluation of the MAX3690ECJ. The EV kit operates from a single +3.3V supply and includes all the external components necessary to interface with TTL inputs and 3.3V PECL outputs.

PD₋, PCLKI

These TTL inputs are high impedance, with a range of 0 to V_{CC} (+3.3V) with respect to ground. All input signal lines are of equal length to minimize propagation-delay skew.

RCLK

See Table 1 for changing reference clock rates. In normal operation with a high-impedance TTL reference source, RCLK should be driven like PCLKI with R2 open and C2 shorted. If RCLK is driven by a 50 Ω TTL source, R2 should be 50 Ω , JU1 should be shorted, and C2 should be shorted. If a non-TTL source is used for RCLK, C2 = 0.1 μ F (ensure trace under C2 is cut) and V_{CC} / 2 should be applied to the stub on the non-ground side of JU1. **Important:** Note that the output of the reference clock generator must swing at least 1.2V peak to peak.

PCLKO

PCLKO is designed to drive a high-impedance TTL input. To drive other I/O standards, a converter on this output is recommended. The PCLKO output is sensitive to capacitance loading (see MAX3690 data sheet for specified capacitance loading).



Maxim Integrated Products 1

**For free samples & the latest literature: <http://www.maxim-ic.com>, or phone 1-800-998-8800.
For small orders, phone 1-800-835-8769.**

MAX3690 Evaluation Kit

SD+, SD-

The PECL outputs have an attenuation and impedance matching network on the EV board that allows 50Ω terminations to ground for oscilloscope interfacing. All signal inputs and outputs use coupled 50Ω transmission lines. All output signal lines are of equal length.

Table 1. Jumper JU3 Functions

SHUNT LOCATION	REFERENCE CLOCK FREQUENCY	CKSET PIN
1-2*	51.84	Connected to a 20kΩ termination to GND
3-4*	38.88	Connected to GND
Open	77.76	Floating

* Pins 1 and 2 are the top two pins.

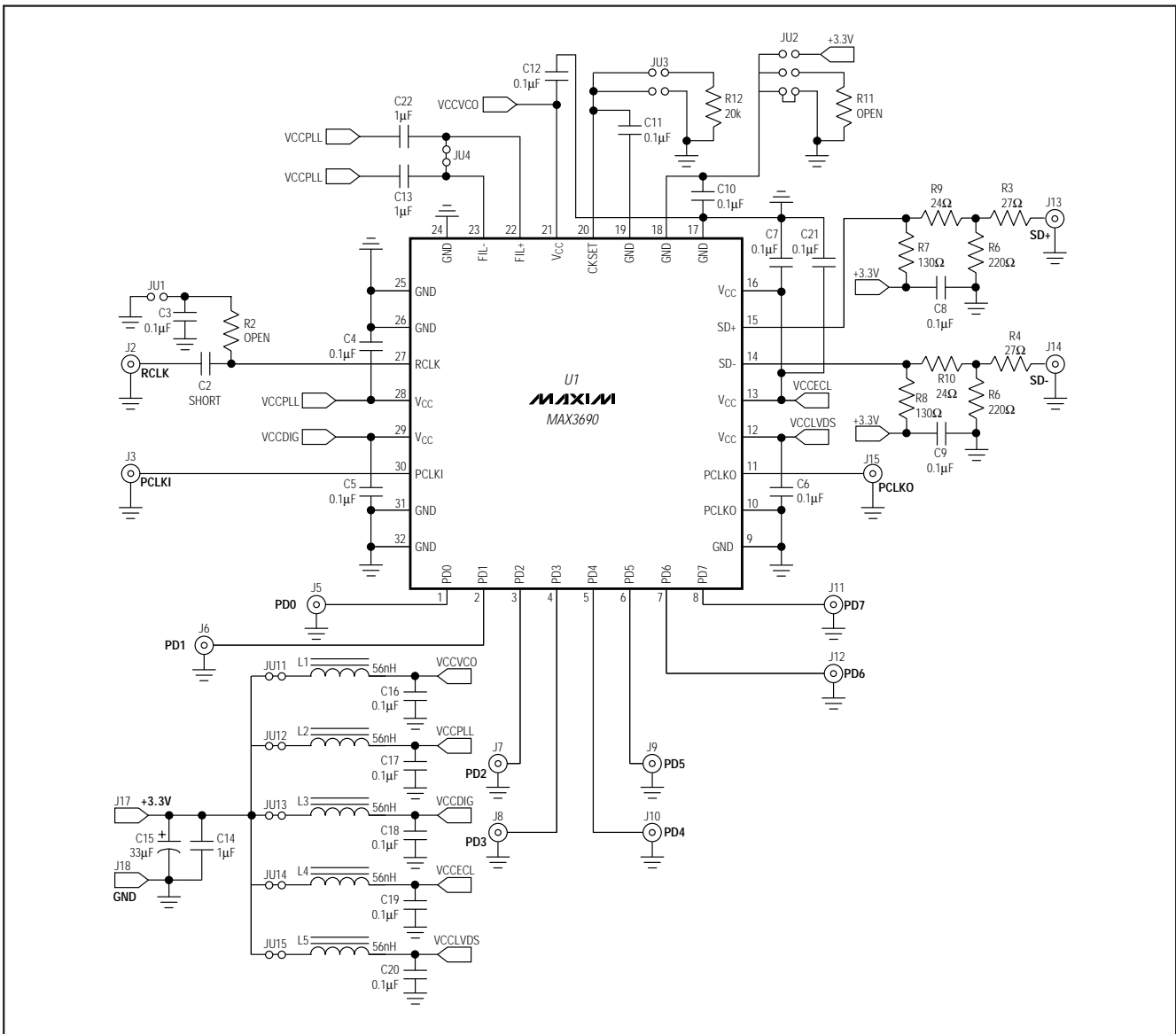

Figure 1. MAX3690 EV Kit Schematic

MAX3690 Evaluation Kit

Evaluates: MAX3690

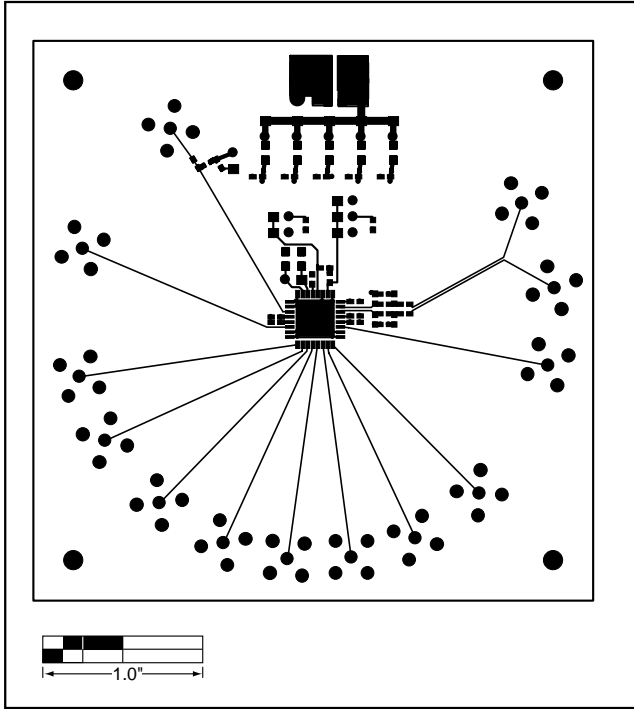

Figure 2. MAX3690 EV Kit PC Board Layout—Component Side

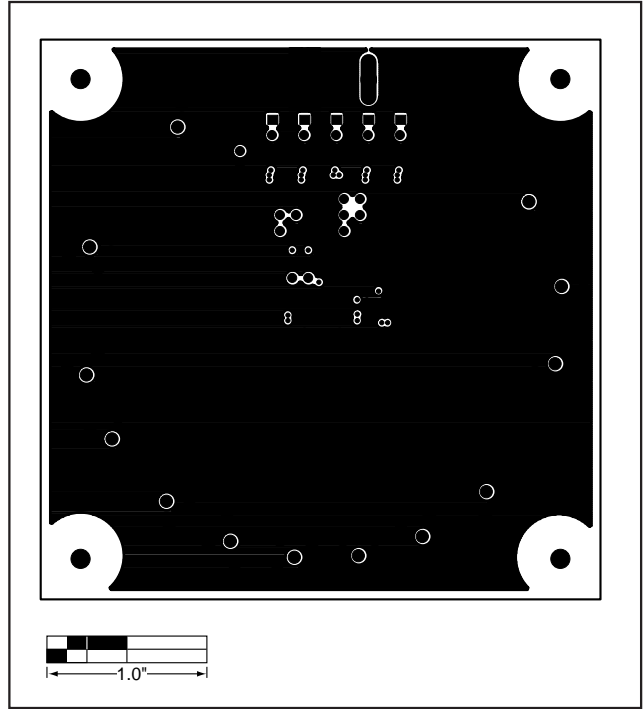

Figure 3. MAX3690 EV Kit PC Board Layout—Solder Side

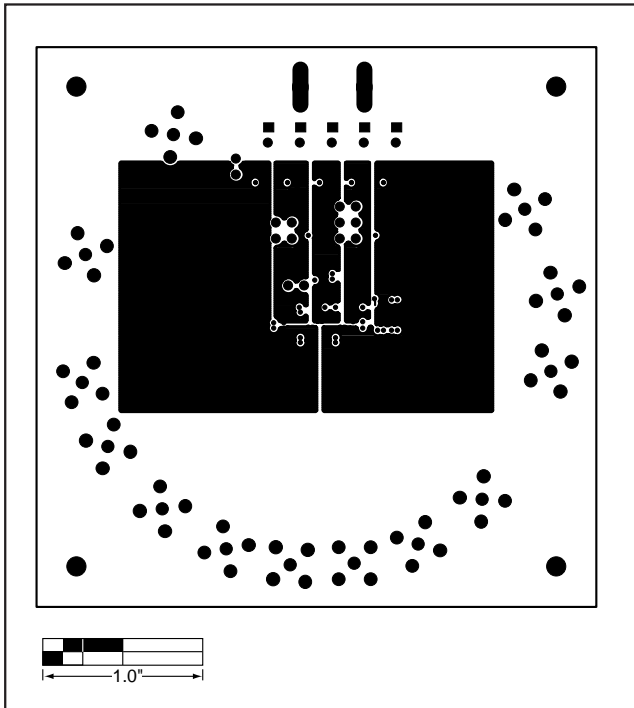

Figure 4. MAX3690 EV Kit PC Board Layout—Power Plane

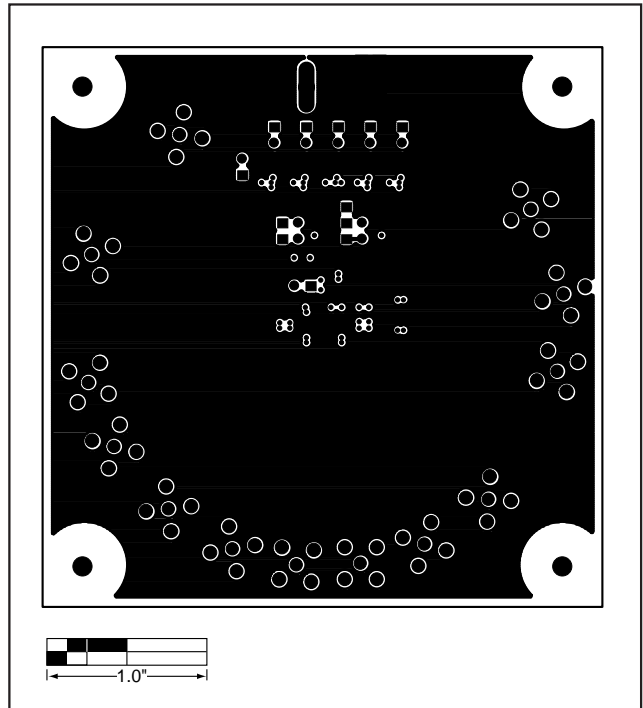

Figure 5. MAX3690 EV Kit PC Board Layout—Ground Plane

MAX3690 Evaluation Kit

Evaluates: MAX3690

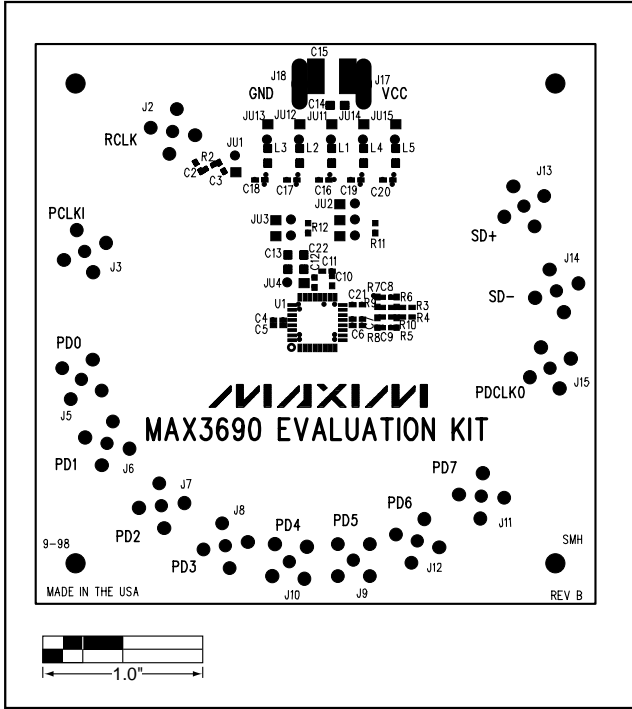

Figure 6. MAX3690 EV Kit PC Board Layout—Silk Screen

Maxim cannot assume responsibility for use of any circuitry other than circuitry entirely embodied in a Maxim product. No circuit patent licenses are implied. Maxim reserves the right to change the circuitry and specifications without notice at any time.

4 _____ Maxim Integrated Products, 120 San Gabriel Drive, Sunnyvale, CA 94086 408-737-7600

© 1999 Maxim Integrated Products

Printed USA

MAXIM is a registered trademark of Maxim Integrated Products.